



MT
T5-PP-K2

**MODUL PENINGKATAN PRESTASI TINGKATAN 5
TAHUN 2024**

**MATEMATIK TAMBAHAN
KERTAS 2**

PERATURAN PEMARKAHAN

Peraturan Pemarkahan ini mengandungi 21 halaman bercetak

- 1 Rajah 1 menunjukkan kerangka tangki air yang dibina menggunakan keluli. Jumlah panjang kerangka keluli ialah 120 m.

Diagram 1 shows a water tank frame built using steel. The total length of the steel frame is 120 m.

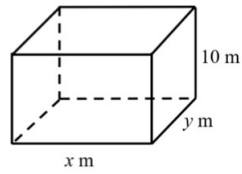

Rajah 1 / Diagram 1

Apabila dinding tangki dipasang, ia mampu menampung air maksimum sebanyak 960 m^3 . Cari nilai x dan y dengan keadaan $x > y$.

When the wall of the tank is installed, it can hold a maximum of 960 m^3 of water. Find the values of x and y where $x > y$.

[6 markah / marks]

No.	SKEMA PEMARKAHAN	Sub Markah	Jumlah Markah
1	<p>Membentuk persamaan linear atau persamaan tak linear</p> <p>$4x + 4y + 40 = 120$ @ $10xy = 960$ P1 ¹</p> <p>$x = 20 - y$ @ $y = 20 - x$ @ $x = \frac{96}{y}$ @ $y = \frac{96}{x}$ P1 ²</p> <p>$10(20 - y)y = 960$ atau $10(20 - x)x = 960$ K1 ¹</p> <p>Hapuskan y atau x (melibatkan satu persamaan linear dan satu persamaan tak linear dalam sebutan x dan y)</p> <p>Selesaikan* ^{kaedah} persamaan kuadratik untuk $b \neq 0$ K1 ²</p> <p>$x = 12, y = 8$ @ $x = 8, y = 12,$ N1</p> <p>$x = 12, y = 8,$ N1</p> <p>Nota: 1. KO,NO,NO - jika tiada kaedah atau pemfaktoran tidak lengkap</p>	6	6

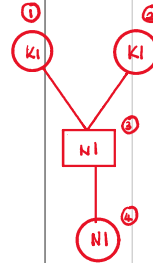

- 2 (a) Buktikan $(\tan 2A)(2 \cos A - \sec A) = 2 \sin A$
 Prove that $(\tan 2A)(2 \cos A - \sec A) = 2 \sin A$

[2 markah / marks]

- (b) Lakar graf $y = -|(\tan 2A)(2 \cos A - \sec A)|$ untuk $0^\circ \leq A \leq 270^\circ$. Seterusnya, lukiskan garis lurus $y = m$ dengan keadaan $m < 0$ yang menghasilkan dua penyelesaian dalam domain $0^\circ \leq A \leq 270^\circ$.
 Nyatakan nilai m .
 Sketch the graph of $y = -|(\tan 2A)(2 \cos A - \sec A)|$ for $0^\circ \leq A \leq 270^\circ$. Hence, draw a straight line of $y = m$ such that $m < 0$ which gives two solutions in the domain $0^\circ \leq A \leq 270^\circ$.
 State the value of m .

[5 markah / marks]

No.	SKEMA PEMARKAHAN	Sub Markah	Jumlah Markah
2(a)	<p>Guna</p> $\tan 2A = \frac{\sin 2A}{\cos 2A} \quad @$ $\sec A = \frac{1}{\cos A} \quad @$ $\cos 2A = 2\cos^2 A - 1 \quad @$ $\sin 2A = 2 \sin A \cos A$ <div style="text-align: center;"> </div>	2	
2(b)	<div style="text-align: center;"> </div> <p>Bentuk graf sinus P1 ¹</p> <p>Amplitud = 2 (maksimum = 2 dan minimum = -2) P1 ²</p> <p>($0^\circ \leq A \leq 270^\circ$). P1 ³</p> <p>Pantulan dan nilai mutlak dalam $0^\circ \leq A \leq 270^\circ$</p> <p>Lakar garis lurus $y = -2$ K1</p> <div style="text-align: center;"> </div> <p>$m = -2$ N1</p> <p><u>Nota:</u></p> <ol style="list-style-type: none"> 1. KO,NO- jika garis lurus $y = -2$ dilukis tidak menggunakan pembaris 2. Abaikan graf diluar julat. 3. Bentuk graf P0, maka P0, P0 	5	7

- 3 Rajah 3 menunjukkan sebuah bulatan berpusat O dengan jejari 4 cm. Segitiga OAB dan OEF adalah kongruen. $\angle JOK = \beta$ dengan keadaan β adalah dalam darjah.
 Diagram 3 shows a circle centered at O with a radius of 4 cm. The triangles OAB and OEF are congruent. $\angle JOK = \beta$ where β is in degree.

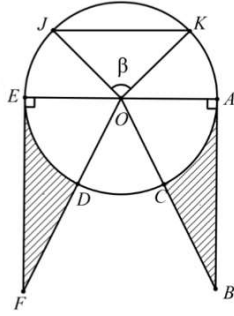

Rajah 3 / Diagram 3

Diberi titik C dan D masing-masing ialah titik tengah bagi OB dan OF .
 Given points C and D are the midpoints of OB and OF respectively.

- (a) Tunjukkan luas tembereng major JK ialah $16\pi - 8\left(\frac{\pi\beta}{180^\circ} - \sin\beta\right)$ cm^2 .

Show that the area of the major segment JK is $16\pi - 8\left(\frac{\pi\beta}{180^\circ} - \sin\beta\right)$ cm^2 .

[4 markah / marks]

- (b) Cari perimeter, dalam cm, bagi kawasan berlorek dalam sebutan π .
 Find the perimeter, in cm, of the shaded area in terms of π .

[3 markah / marks]

No.	SKEMA PEMARKAHAN	Sub Markah	Jumlah Markah
3(a)	<p>Mencari luas sektor @ luas segitiga</p> <p>Luas sektor, $L_{OK} = \frac{1}{2}(4)^2 \left(\beta \times \frac{\pi}{180^\circ} \right)$</p> <p>ATAU (P1)</p> <p>Luas segitiga, $L_{\Delta OK} = \frac{1}{2}(4)^2 (\sin \beta)$</p> <p><u>Luas bulatan</u> ATAU <u>Luas tembereng minor *</u></p> <p>$\pi(4^2)$ $8 \left(\frac{\beta\pi}{180^\circ} - \sin \beta \right)$</p> <p style="text-align: center;">(K1) ⁰</p> <p>Luas bulatan - luas tembereng minor*</p> <p>$\pi(4^2) - 8 \left(\beta \times \frac{\pi}{180^\circ} - \sin \beta \right)$</p> <p>$16\pi - 8 \left(\frac{\pi\beta}{180^\circ} - \sin \beta \right)$</p> <p style="text-align: center;">(K1) ²</p> <p style="text-align: center;">(N1)</p>	4	<div style="display: flex; justify-content: space-around; align-items: center;"> <div style="text-align: center;">(K1) ⁰</div> <div style="text-align: center;">(K1) ²</div> </div> <div style="text-align: center; margin-top: 10px;">(N1)</div>
3(b)	<p>Mencari panjang AB@EF dan $\angle AOB$ @ $\angle EOF$</p> <p>$4\sqrt{3}$ cm dan $\frac{\pi}{3}$ rad / 60°</p> <p style="text-align: center;">ATAU (N1)</p> <p><u>Panjang lengkok DE @ AC (guna rumus $s = r\theta$)</u></p> <p>$4 \left(\frac{\pi}{3} \right)$</p> <p>Hasil tambah AB+BC+panjang lengkok AC*+EF+FD</p> <p>+panjang lengkok DE*</p> <p>$4\sqrt{3} + 4 + \frac{4\pi}{3} + 4\sqrt{3} + 4 + \frac{4\pi}{3}$ @ $2 \left(4\sqrt{3} + 4 + \frac{4\pi}{3} \right)$ (K1)</p> <p style="text-align: center;">(N1)</p> <p style="text-align: center;">$21.86 + \frac{8}{3}\pi/8 + 8\sqrt{3} + \frac{8}{3}\pi/8 \left(\sqrt{3} + \frac{\pi}{3} + 1 \right)$</p>	3	7

- 4 Rajah 4 menunjukkan laluan trek berbasikal di sebuah taman rekreasi yang diwakili oleh lengkung $y = x^2 \left(\frac{3}{2}x - 2 \right) + \frac{5}{2}$. Apabila tiba di titik P , Hazim menggunakan laluan PQ yang merupakan tangen kepada trek basikal tersebut.

Diagram 4 shows the route of a cycling track at a recreational park represented by a curve $y = x^2 \left(\frac{3}{2}x - 2 \right) + \frac{5}{2}$. When arriving at point P , Hazim used the path PQ which is tangent to the cycling track.

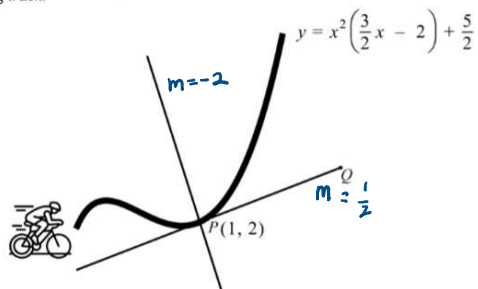

Rajah 4/ Diagram 4

Satu terusan berserenjang dengan laluan PQ dibina melalui titik P diwakili oleh persamaan $y + 2x = q^2 + 3$.

A canal is built which is perpendicular to path PQ passing through point P is represented by the equation $y + 2x = q^2 + 3$.

Cari,
Find,

- (a) persamaan laluan PQ ,
the equation of path PQ .

[4 markah / marks]

- (b) nilai q , jika $q > 0$.
value of q , if $q > 0$.

[3 markah / marks]

No.	SKEMA PEMARKAHAN	Sub Markah	Jumlah Markah
4(a)	<p>Bezakan $y = \frac{3}{2}x^2 - 2x^2 + \frac{5}{2}$</p> <p>$\frac{dy}{dx} = \frac{9}{2}x - 4x$</p> <p>Mesti betul sekurang-kurangnya satu sebutan dengan kuasa x berkurang satu</p> <p>$\frac{dy}{dx} = \frac{9}{2}(1)^2 - 4(1)$</p> <p>Gantikan $x = 1$ dalam $\frac{dy}{dx}$</p> <p>$\frac{dy}{dx} = \frac{1}{2}$</p> <p>$y = \frac{1}{2}x + \frac{3}{2}$ @sctara</p> <p>Guna $y - 2 = \frac{1}{2}(x - 1)$</p> <p>$2 = \frac{1}{2}(1) + c$</p> <p>Selesaikan untuk c</p> <p>$c = \frac{3}{2}$ ✓</p> <p>Diagram: K1 (0) → K1 (1) → K1 (2) → N1</p>	4	
4(b)	<p>Guna $\begin{pmatrix} 1 \\ 2 \end{pmatrix} (m_y) = -1$</p> <p>$m_y = -2$</p> <p>Bandungkan pintasan-y</p> <p>$q^2 + 3 = 4$</p> <p>@Gantikan (1,2) dalam persamaan</p> <p>$q = 1$</p> <p>Diagram: P1 → K1 → N1</p> <p>$21.86 + \frac{8}{3}\pi/8 + 8\sqrt{3} + \frac{8}{3}\pi/8 \left(\sqrt{3} + \frac{\pi}{3} + 1 \right)$</p>	3	7

- 5 Rajah 5 menunjukkan sisi empat $OABC$ dengan keadaan garis lurus OB bersilang dengan garis lurus AD di E .
 Diagram 5 shows a quadrilateral $OABC$ such that the straight line OB intersects the straight line AD at E .

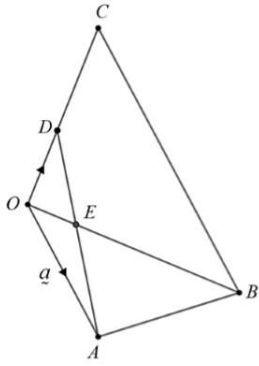

Rajah 5 / Diagram 5



Diberi bahawa $OA:CB=1:2$, $OC:OD=3:1$, $\vec{OD}=\vec{d}$, $\vec{AE}=m\vec{AD}$ dan $\vec{OE}=n\vec{OB}$.
 Given that $OA:CB=1:2$, $OC:OD=3:1$, $\vec{OD}=\vec{d}$, $\vec{AE}=m\vec{AD}$ and $\vec{OE}=n\vec{OB}$.

- (a) Tunjukkan $\vec{OE}=(1-m)\vec{a}+m\vec{d}$
 Show that $\vec{OE}=(1-m)\vec{a}+m\vec{d}$

[2 markah / marks]

- (b) Cari,
 Find,
 (i) nilai m dan n ,
 the value of m and of n ,
 (ii) $DE:EA$.

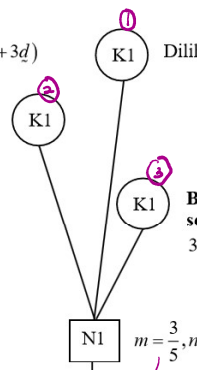
[5 markah / marks]

No.	SKEMA PEMARKAHAN	Sub Markah	Jumlah Markah
5(a)	<p>Tuliskan hukum segitiga $\triangle AOD \sim \triangle AOE$ $\vec{AD} = \vec{AO} + \vec{OD}$ @ $\vec{OE} = \vec{OA} + \vec{AE}$</p> <p>$\vec{OE} = (1-m)\vec{a} + m\vec{d}$</p> 	2	
5(b)(i)	<p>$\vec{OE} = n(2\vec{a} + 3\vec{d})$</p> <p>Samakan \vec{OE} $n(2\vec{a} + 3\vec{d}) = (1-m)\vec{a} + m\vec{d}$</p> <p>Banding dan selesaikan a dan d $3n = m$ dan $2n = 1-m$</p> <p>$m = \frac{3}{5}, n = \frac{1}{5}$</p> 	4	
5(b)(ii)	<p>$2:3$</p> 	1	
			7

- 6 Rajah 6 menunjukkan lokus berbentuk parabola bagi dua ekor katak berbeza spesies.
Diagram 6 shows a parabolic locus for two frogs of different species.

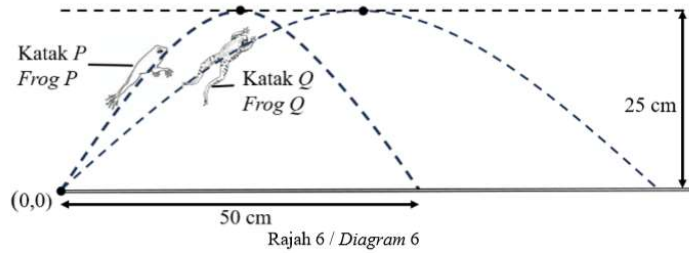

Diberi tinggi maksimum lompatan bagi kedua-dua ekor katak ialah 25 cm dan jarak lompatan mengufuk bagi katak P ialah 50 cm.
Given that the maximum height of the leap for both frogs is 25 cm and the horizontal leap distance for frog P is 50 cm.

- (a) Tuliskan fungsi kuadratik, $f(x)$, yang mewakili lokus katak P dalam bentuk am.
Write a quadratic function, $f(x)$, which represents the locus of frog P in general form.
[3 markah / marks]
- (b) Lokus katak Q diwakili oleh $g(x) = -\frac{1}{64}x^2 + \frac{5}{4}x$. Ungkapkan $g(x)$ dalam bentuk verteks, seterusnya nyatakan jarak mengufuk lompatan katak Q, dalam cm.
The locus of frog Q is represented by $g(x) = -\frac{1}{64}x^2 + \frac{5}{4}x$. Express $g(x)$ in vertex form, hence state the horizontal leaping distance of frog Q, in cm.
[3 markah / marks]
- (c) Jika a_1 dan a_2 masing-masing ialah pekali x^2 bagi $f(x)$ dan $g(x)$, nyatakan kesan perubahan pada jarak mengufuk berdasarkan nilai pekali x^2 kedua-dua fungsi tersebut. Beri justifikasi anda.
If a_1 and a_2 are the coefficients of x^2 for $f(x)$ and $g(x)$ respectively, state the effect of changes on the horizontal distance based on the value of the coefficients of x^2 of the two functions. Give your justification.
[2 markah / marks]

No.	SKEMA PEMARKAHAN	Sub Markah	Jumlah Markah
6(a)	<p>Gantikan (0,0) @ (50,0) dalam $f(x)$ *Jika guna persamaan kuadratik bentuk pintasan ganti (25,25)</p> <p>$0 = a(0 - 25)^2 + 25$ @ $0 = a(50 - 25)^2 + 25$ @ $25 = a(25)(25 - 50)$</p> <p style="text-align: center;">K1</p> <p style="text-align: center;">N1 $a = -\frac{1}{25}$</p> <p style="text-align: center;">N1 * $f(x) = -\frac{1}{25}x^2 + 2x$ ✓</p>	3	
6(b)	<p>$g(x) = -\frac{1}{64} \left[x^2 - 80x + \left(\frac{-80}{2}\right)^2 - \left(\frac{-80}{2}\right)^2 \right]$</p> <p style="text-align: center;">K1</p> <p style="text-align: center;">$g(x) = -\frac{1}{64}(x - 40)^2 + 25$ N1</p> <p>Jarak lompatan katak Q ialah 80 cm N1</p>	2	
6(c)	<p>Nilai a bertambah, Jarak mengufuk bertambah/Vice versa N1</p> <p>Justifikasi : $a_1 < a_2 @ -\frac{1}{25} < -\frac{1}{64}$ /Vice versa N1</p>	2	
			8

- 7 Rajah 7 menunjukkan sebuah rombus $ABCD$ dilukis pada satu satah *Cartes*.
Diagram 7 shows a rhombus $ABCD$ drawn on a Cartesian plane.

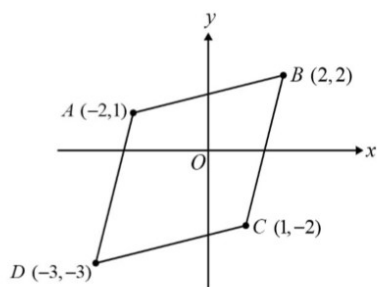

Rajah 7 / Diagram 7

- (a) Tentukan pasangan garis serenjang dengan hanya menggunakan bucu-bucu rombus.
 Buktikan dengan pengiraan untuk menyokong jawapan anda.
Determine the pair of perpendicular lines just by using all vertices of the rhombus. Prove with calculations to support your answer.
- [2 markah / marks]
- (b) Cari luas rombus $ABCD$.
Find the area of rhombus $ABCD$.
- [2 markah / marks]
- (c) (i) Titik P bergerak di sepanjang bulatan dengan keadaan nisbah $PA : PB = 1 : 2$.
 Cari persamaan lokus bagi titik P .
Point P moves along a circle such that $PA : PB = 1 : 2$. Find the equation of the locus of point P .
- (ii) Seterusnya, cari koordinat apabila lokus P memotong paksi- x .
Hence, find the coordinates when locus P intersects the x -axis.

[4 markah / marks]

No.	SKEMA PEMARKAHAN	Sub Markah	Jumlah Markah
7(a)	<p><i>(tersirat)</i></p> $m_{AC} = \frac{1 - (-2)}{-2 - 1} \quad @ \quad m_{BD} = \frac{2 - (-3)}{2 - (-3)}$ <p>dan</p> $(m_{AC})(m_{BD}) = -1$ <p style="text-align: right;"><i>AC</i> AD dan <i>BD</i></p>		2
7(b)	<p>Guna $\frac{1}{2} (x_1 - x_2) - (y_1 - y_2)$</p> $\frac{1}{2} \left \frac{(-2(2) + 2(-2) + 1(-3) + (-3)(1)) - (2(1) + 1(2) + (-2)(-3) + (-2)(-3))}{15} \right $		2
7(c)(i)	<p>Guna rumus jarak</p> $2\sqrt{(x - (-2))^2 + (y - 1)^2} \quad @ \quad \sqrt{(x - 2)^2 + (y - 2)^2}$ <p style="text-align: center;"><i>PA</i> <i>PB</i></p> $3x^2 + 3y^2 + 20x - 4y + 12 = 0$		2
7(c)(ii)	<p>Gantikan $y = 0$</p> $3x^2 + 3(0)^2 + 20x - 4(0) + 12 = 0 \text{ dan}$ <p>Selesaikan persamaan kuadrat</p> $3x^2 + 20x + 12 = 0$		2
			8

+ (-3)(1)

- 8 Rajah 8(a) menunjukkan sebuah bekas air plastik, manakala Rajah 8(b) menunjukkan keratan rentas bagi bekas air plastik dalam Rajah 8(a).
 Diagram 8(a) shows a plastic water container, while Diagram 8(b) shows the cross section of the plastic water container in Diagram 8(a).



Rajah 8(a) / Diagram 8(a)

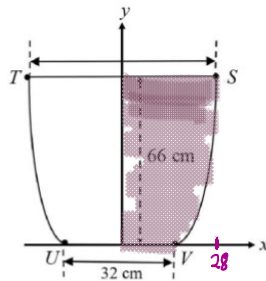

Rajah 8(b) / Diagram 8 (b)

Diberi persamaan sisi bekas air plastik ialah $y = \frac{1}{8}x^2 - 32$.

Given the equation of the side of the plastic water container is $y = \frac{1}{8}x^2 - 32$.

Cari,

Find,

- (a) luas $STUV$, dalam cm^2 , keratan rentas bekas air plastik dalam Rajah 8(b).
 the area of $STUV$, in cm^2 of the cross section of the plastic water container in Diagram 8(b). [5 markah / marks]
- (b) isipadu, dalam cm^3 , bagi bekas air plastik dalam Rajah 8(a) dalam sebutan π . Seterusnya, cari kos cecair yang diperlukan jika harga bagi setiap $80\pi \text{ cm}^3$ cecair itu ialah RM 1.20.
 the volume, in cm^3 , for the plastic water container in Diagram 8(a) in terms of π . Hence, find the cost of the liquid needed if the price for each $80\pi \text{ cm}^3$ of the liquid is RM 1.20 [5 markah / marks]

No.	SKEMA PEMARKAHAN	Sub Markah	Jumlah Markah
8(a)	<p style="text-align: center;">ALTERNATIF A</p> <p>$x = 28$ @ $A_2 = 66 \times 28$ (P1) $A_2 = 1848$</p> <p>Kamirkan $\frac{1}{8}x^2 - 32$ terhadap x Mesti betul sekurang-kurangnya satu sebutan dengan kuasa x bertambah satu</p> <p style="text-align: center;"> </p> <p style="text-align: center;">ALTERNATIF B</p> <p>$x = (8y + 256)^{\frac{1}{2}}$ (P1) tersirat</p> <p>$\int_0^{66} (8y + 256)^{\frac{1}{2}} dy$ (P1)</p> <p>Kamirkan $(8y + 256)^{\frac{1}{2}}$ terhadap y Mesti betul sekurang-kurangnya satu sebutan dengan kuasa y bertambah satu</p> <p style="text-align: center;"> </p>	5	

No.	SKEMA PEMARKAHAN	Sub Markah	Jumlah Markah
8(b)	<p> $x^2 = 8y + 256$ </p> <p> P1 dilihat </p> <p> Kamirkan $8y + 256$ terhadap y </p> <p> K1 </p> <p> dan guna had \int_0^{66} ke dalam kamiran. </p> <p> N1 34320π </p> <p> $\frac{*34320\pi}{80\pi} \times 1.20$ </p> <p> P1 </p> <p> N1 514.80 </p>	5	10

- 9 Jadual 9 menunjukkan nilai-nilai bagi dua pemboleh ubah x dan y , yang diperolehi daripada suatu eksperimen. Pemboleh ubah x dan y dihubungkan oleh persamaan $y = \frac{1}{k\sqrt{x}} + h\sqrt{x}$, dengan keadaan h dan k ialah pemalar.
 Table 9 shows the values of two variables x and y , obtained from an experiment. The variables x and y are related by the equation $y = \frac{1}{k\sqrt{x}} + h\sqrt{x}$, such that h and k are constants.

x	4	6	8	10	12	14
y	0.35	0.81	1.06	1.36	1.63	1.76

Jadual 9 / Table 9

- (a) Berdasarkan Jadual 9, bina satu jadual bagi nilai $y\sqrt{x}$.
 Based on Table 9, construct a table for the values of $y\sqrt{x}$.
 [1 markah / mark]
- (b) Plot $y\sqrt{x}$ melawan x , menggunakan skala 2 cm kepada 2 unit pada paksi- x dan 2 cm kepada 1 unit pada paksi- y .
 Seterusnya, lukis garis lurus penyuaiian terbaik.
 Plot $y\sqrt{x}$ against x , using a scale of 2 cm to 2 unit on the x -axis and 2 cm to 1 unit on the y -axis.
 Hence, draw the line of best fit.
 [3 markah / marks]
- (c) Dengan menggunakan graf di (b), cari nilai
 By using the graph in (b), find the value of
- k dan h ,
 k and h ,
 - y apabila $x = 9$.
 y when $x = 9$.
- [6 markah / marks]

No.	SKEMA PEMARKAHAN	Sub Markah	Jumlah Markah								
9(a)	<table border="1"> <tr> <td>$y\sqrt{x}$</td> <td>0.70</td> <td>1.98</td> <td>3.00</td> <td>4.30</td> <td>5.65</td> <td>6.59</td> <td>N1</td> </tr> </table>	$y\sqrt{x}$	0.70	1.98	3.00	4.30	5.65	6.59	N1	1	
$y\sqrt{x}$	0.70	1.98	3.00	4.30	5.65	6.59	N1				
9(b)	<p>Graf garis lurus $y\sqrt{x}$ melawan x dilukis</p> <ul style="list-style-type: none"> Paksi-paksi betul dan skala seragam. sekurang-kurangnya 1*titik diplot dengan betul. <p>6* titik diplot dengan betul</p> <p>Garis lurus penyuaiian terbaik sekurang-kurangnya 2 titik diplotkan <i>diletakkan garis / selimbelang pada</i></p>	3									
9(c)(i)	<p>$y\sqrt{x} = hx + \frac{1}{k}$ P1</p> <p>Cari * $m = h$ K1</p> <p>$h = \frac{3}{5} / 0.6$ N1</p> <p>Cari * $c = \frac{1}{k}$ K1</p> <p>$k = -0.5882$ N1</p> <p>Syarat $-1.5 \leq c \leq -1.7$ $-1.7 \leq c \leq -1.5$</p>	5									
9(c)(ii)	<p>$y = 1.23$ N1</p>	1	10								

NO 1 NO 4 NO 8 NO 9

* NO 4 NO 8 NO 9

Graf untuk soalan 9

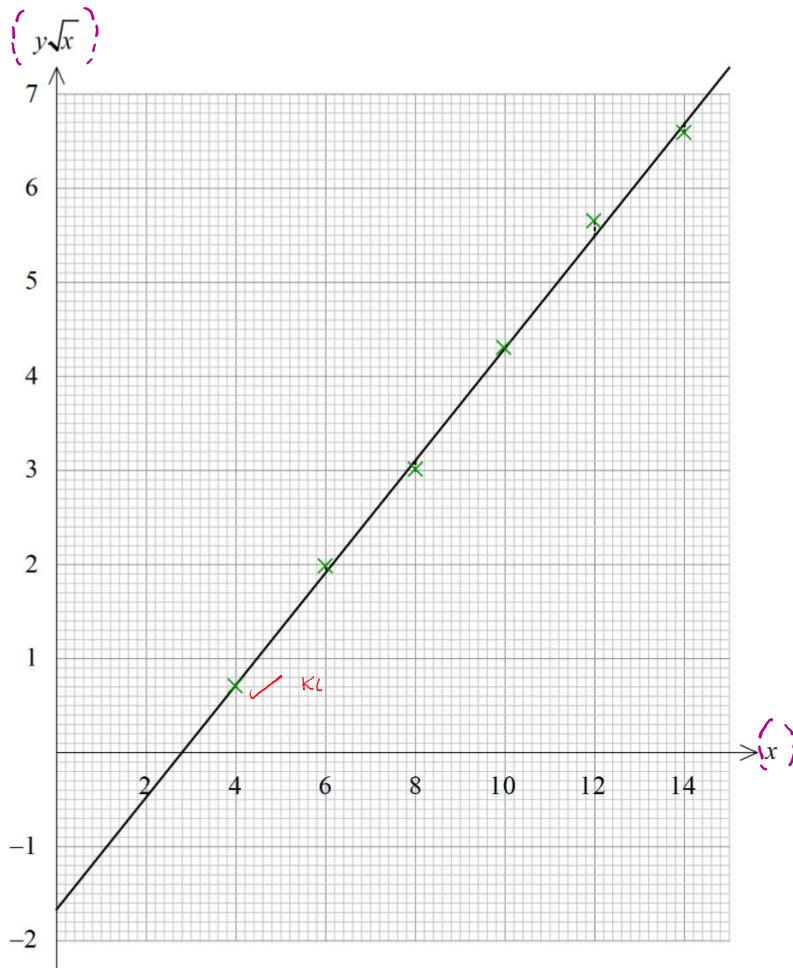

- 10 Rajah 10 menunjukkan empat buah silinder yang berlainan saiz. Setiap silinder mempunyai jejari x m dan tinggi bagi setiap silinder yang berturutan adalah separuh daripada tinggi silinder sebelumnya. Tinggi silinder pertama ialah h m.
 Diagram 10 shows four cylinders of different sizes. Each cylinder has a radius of x m and the height of each successive cylinder is half of the height of the previous cylinder. The height of the first cylinder is h m.

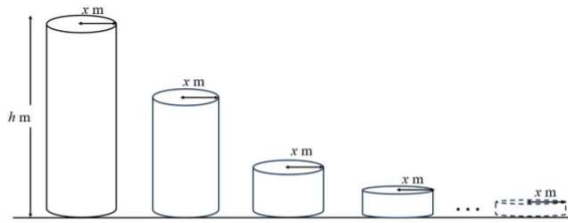

Rajah 10 / Diagram 10

- (a) Ungkapkan x dalam sebutan h jika hasil tambah isipadu empat silinder pertama ialah $480\pi \text{ m}^3$.
 Express x in terms of h if the sum of the first four volumes of the cylinders is $480\pi \text{ m}^3$.
 [3 markah / marks]
- (b) Seterusnya, cari nilai h jika diberi nisbah jejari kepada tinggi silinder yang pertama ialah 1 : 4.
 Hence, find the value of h if the ratio of the radius to the height of the first cylinder is 1 : 4.
 [3 markah / marks]
- (c) (i) Cari bilangan silinder yang penuh berisi air diperlukan untuk menampung 1600 m^3 air.
 Find the number of cylinders that can completely hold water needed to accommodate 1600 m^3 of water.
- (ii) Seterusnya, cari baki isipadu air dalam m^3 .
 Hence, find the volume of the remaining water, in m^3 .
 [Guna / Use $\pi = 3.142$]
 [4 markah / marks]

No.	SKEMA PEMARKAHAN	Sub Markah	Jumlah Markah
10(a)	<p> $\pi x^2 h$ dan $\pi x^2 \frac{h}{2}$ dan $\pi x^2 \frac{h}{4}$ dan $\pi x^2 \frac{h}{8}$ atau $r = \frac{1}{2} / 0.5$ </p> <p style="text-align: right;">(P1)</p> <p style="text-align: center;">ALTERNATIF A</p> <p> $\pi x^2 h + \pi x^2 \frac{h}{2} + \pi x^2 \frac{h}{4} + \pi x^2 \frac{h}{8} = 480\pi$ </p> <p style="text-align: right;">(K1)</p> <p style="text-align: center;"> </p> <p style="text-align: center;">(N1)</p> <p style="text-align: center;">$x = \frac{16}{\sqrt{h}}$</p> <p style="text-align: center;">ALTERNATIF B</p> <p> $\frac{\pi x^2 h \left[1 - \left(\frac{1}{2} \right)^4 \right]}{1 - \frac{1}{2}} = 480\pi$ </p> <p style="text-align: right;">(K1)</p> <p style="text-align: center;"> </p> <p style="text-align: center;">(N1)</p> <p style="text-align: center;">$x = \frac{16}{\sqrt{h}}$</p>	3	
10(b)	<p> $x = \frac{1}{4} h$ </p> <p style="text-align: right;">(P1) dilihat</p> <p>Bandingkan dan selesaikan — nampak ada pergerakan pengiraan.</p> <p> $\frac{16}{\sqrt{h}} = \frac{1}{4} h$ </p> <p style="color: red; font-size: 1.2em;">$h^{3/2} = 64$</p> <p style="text-align: right;">(K1)</p> <p style="text-align: center;"> </p> <p style="text-align: center;">(N1) 16</p>	3	

No.	SKEMA PEMARKAHAN	Sub Markah	Jumlah Markah
10(c)(i)	<p>Guna rumus $S_n \leq 1600$</p> $\frac{256\pi \left[1 - \left(\frac{1}{2}\right)^n \right]}{1 - \frac{1}{2}} \leq 1600$		
10(c)(ii)	<p>Gantikan $n = 7$ rumus S_n</p> $\frac{256\pi \left[1 - \left(\frac{1}{2}\right)^7 \right]}{1 - \frac{1}{2}} \leq 1596.14$ <p>< 1600</p>	4	
			10

$$\left(1 - \frac{1}{2}^n\right) \leq \frac{800}{256\pi}$$

$$-\frac{1}{2}^n \leq \frac{25 - 8\pi}{8\pi}$$

$$\frac{1}{2}^n \geq \frac{8\pi - 25}{8\pi}$$

$$n(-0.3010) \geq -2.2772$$

$$n \leq 7.57$$

- 11 (a) Persatuan STEM SMK Harmoni menjalankan tinjauan tentang tempoh hayat bagi satu jenama sel kering tertentu. Suatu sampel 4 biji sel kering dipilih secara rawak. Rajah 11 menunjukkan keputusan tinjauan dengan keadaan X mewakili bilangan sel kering yang mempunyai jangka hayat kurang daripada 2 bulan. STEM society of SMK Harmoni conducted a survey about the lifespan for a brand of dry cell. A sample of 4 dry cells are randomly selected. Diagram 11 shows the survey results and X represents the number of dry cell which has lifespan less than 2 months.

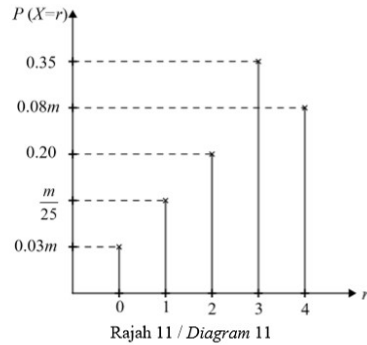

- (i) Cari nilai m .
Find the value of m .
- (ii) Cari kebarangkalian bahawa lebih daripada 3 bateri mempunyai jangka hayat kurang daripada 2 bulan.
Find the probability that more than 3 batteries with lifespan less than 2 months.
- (iii) Cari kebarangkalian bahawa selebih-lebihnya 2 biji bateri mempunyai jangka hayat kurang daripada 2 bulan.
Find the probability that at most 2 batteries with lifespan that less than 2 months.
- [5 markah / marks]
- 11 (b) Diberi bahawa markah ujian Matematik bagi 120 orang murid bertabur secara normal dengan min 86 dan sisihan piawai 10. Given that the marks for Mathematics test for 120 students are normally distributed with a mean of 86 and a standard deviation of 10.
- (i) Wakilkan kebarangkalian bahawa seorang murid yang dipilih secara rawak itu mendapat markah antara 80 dengan 90 dengan melakar graf taburan normal piawai. Represent the probability that a randomly selected student scores between 80 and 90 by sketching a graph of the standard normal distribution.
- (ii) Jika murid dengan markah tidak kurang daripada 80 markah akan dipilih untuk menyertai suatu kuiz Matematik, hitung bilangan murid yang akan dipilih untuk menyertai kuiz tersebut. If students whose marks not less than 80 will be selected to join a Mathematics quiz, calculate the number of students that will be selected.
- [5 markah / marks]

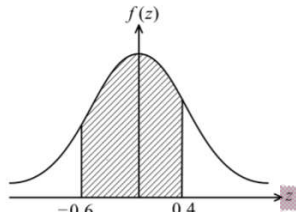
No.	SKEMA PEMARKAHAN	Sub Markah	Jumlah Markah
11(a)(i)	$0.35 + 0.08m + 0.20 + \frac{m}{25} + 0.03m = 1$ <div style="text-align: right;"> P1 N1 </div>	2	
11(a)(ii)	0.2400 N1	1	
11(a)(iii)	$P(X \leq 2) = P(X=0) + P(X=1) + P(X=2)$ $P(X \leq 2) = 1 - P(X=4) - P(X=3)$ <div style="text-align: right;"> K1 N1 </div>	2	
11(b)(i)	$P\left(\frac{80-86}{10} \leq z \leq \frac{90-86}{10}\right)$ <p>@</p> $P(-0.6 \leq z \leq 0.4)$ <div style="text-align: center;">  <p>Graf Normal Piawai berbentuk loceng dan z dilihat pada paksi mengufuk. Graf mesti dilukis menggunakan pembaris</p> </div> <div style="text-align: right;"> P1 N1 </div>	2	
11(b)(ii)	$P(Z \geq 0.6)$ <div style="text-align: right;"> K1 N1 N1 </div>	3	
			10

15

- 12 Rajah 12 menunjukkan sebuah bulatan berjari 7 cm yang berpusat di O . Sudut ABC adalah sudut cakah.
Diagram 12 shows a circle with radius 7 cm centred at O . The angle of ABC is an obtuse angle.

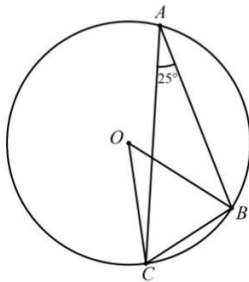

Rajah 12 / Diagram 12

Diberi panjang perentas $AB = 8.14$ cm.
Given the length of chord $AB = 8.14$ cm.

- (a) (i) Cari panjang dalam cm, perentas BC .
Find the length in cm, of chord BC .
- (ii) Seterusnya, cari luas segitiga OBC dengan menggunakan rumus Heron.
Hence, find the area of triangle OBC by using Heron's formula. [4 markah / marks]
- (b) Diberi luas segitiga ABC ialah 20.98 cm². Hitung $\angle ABC$.

(ii) Seterusnya, cari luas segitiga OBC dengan menggunakan rumus Heron.
Hence, find the area of triangle OBC by using Heron's formula. [4 markah /marks]

(b) Diberi luas segitiga ABC ialah 20.98 cm^2 . Hitung $\angle ABC$.
Given that the area of triangle ABC is 20.98 cm^2 . Calculate $\angle ABC$. [3 markah /marks]

(c) Lakarkan sebuah segitiga $A'B'C'$ yang mempunyai bentuk berbeza daripada segitiga ABC dengan keadaan $C'B' = CB$, $A'B' = AB$ dan $\angle C'A'B' = \angle CAB$.
Seterusnya, cari nilai bagi $\angle B'C'A'$.
Sketch a triangle $A'B'C'$ which has a different shape from triangle ABC such that $C'B' = CB$, $A'B' = AB$ and $\angle C'A'B' = \angle CAB$.
Hence, find the value of $\angle B'C'A'$. [3 markah /marks]

No.	SKEMA PEMARKAHAN	Sub Markah	Jumlah Markah
12(a)(i)	<p>Guna petua kosinus untuk mencari BC</p> <p>@</p> <p>Guna petua sinus untuk mencari BC</p> <hr/> $BC^2 = 7^2 + 7^2 - 2(7)(7)\cos 50^\circ$ <p>@</p> $\frac{BC}{\sin 50^\circ} = \frac{7}{\sin 65^\circ}$	2	
12(a)(ii)	<p>Guna $s = \frac{a+b+c}{2}$</p> $s = \frac{7+7+5.92}{2}$ <p>Guna rumus Heron</p> $\sqrt{9.96*(9.96*-7)(9.96*-7)(9.96*-5.92*)}$ <p>18.78</p>	3	
12(b)	<p>$\frac{1}{2}(8.14)(5.92*)\sin B = 20.98$</p> <p>119.40° (cakadh)</p>	2	

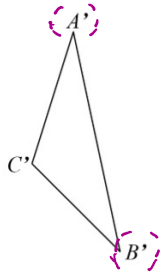
No.	SKEMA PEMARKAHAN	Sub Markah	Jumlah Markah
12(c)	 <p data-bbox="532 420 743 514"><u>Nota:</u> 1. $\angle A'C'B'$ adalah cakak. 2. Sisi-sisi dilakar dengan pembaris</p> <p data-bbox="548 556 669 598">N1 NMA</p> <p data-bbox="289 682 435 709"><u>Guna petua sinus</u></p> $\frac{\sin \angle B'C'A'}{8.14} = \frac{\sin 25^\circ}{5.92}$ <p data-bbox="535 688 592 745">K1</p> <p data-bbox="381 844 532 871">144.45° ↔ 144.47°</p> <p data-bbox="535 844 592 882">N1</p>	3	10

- 13 Rajah 13 menunjukkan carta palang bagi harga jualan tiga jenis kek di Kedai Kek Sarah pada tahun 2020 dan 2021.
 Diagram 13 shows a bar chart of selling price for three types of cakes in Kedai Kek Sarah in the year 2020 and 2021.

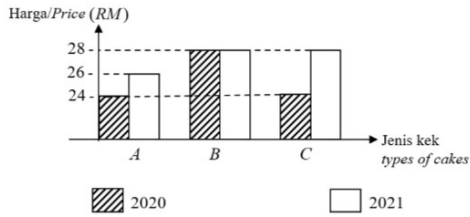

Rajah 13 / Diagram 13

- (a) Dengan menggunakan tahun 2020 sebagai tahun asas, kira
 By using the year 2020 as the base year, calculate
- indeks harga bagi setiap jenis kek,
 the price indices for each type of cakes,
 - indeks gubahan harga jualan semua jenis kek pada tahun 2021.
 the composite index of selling price of all the types of cakes for the year 2021.
 [5 markah / marks]
- (b) Diberi bahawa jumlah jualan semua jenis kek meningkat sebanyak 5% dari tahun 2021 ke tahun 2022, cari indeks gubahan harga jualan kek pada tahun 2022 berasaskan tahun 2020.
 Given that the total sales of all types of cakes increase by 5% from the year 2021 to the year 2022, find the composite index of the selling price of the cakes for the year 2022 based on the year 2020.
 [2 markah / marks]
- (c) Jualan semua jenis kek itu merosot sebanyak m % dari tahun 2022 ke tahun 2023. Diberi bahawa jumlah jualan semua kek itu pada tahun 2020 ialah RM 58 000 dan pada tahun 2023 ialah RM 49 300. Tentukan nilai m .
 The sales of all types of cakes decrease by m % from the year 2022 to the year 2023. Given that the sales for all cakes in the year 2020 was RM 58 000 and in the year 2023 is RM 49 300. Determine the value of m .
 [3 markah / marks]

No.	SKEMA PEMARKAHAN	Sub Markah	Jumlah Markah
13(a)(i)	108.33 [N1] 100 [N1] 116.67 [N1]	3	
13(a)(ii)	$\frac{(108.33 \times 1) + (100 \times 1) + (116.67 \times 1)}{1+1+1}$ <div style="display: flex; align-items: center; justify-content: center;"> <div style="text-align: center;"> <p>(K1)</p> <p> </p> <p>[N1] 108.33</p> </div> </div>	2	
13(b)	$\frac{105 \times 108.33}{100}$ <div style="display: flex; align-items: center; justify-content: center;"> <div style="text-align: center;"> <p>(K1)</p> <p> </p> <p>[N1] 113.75</p> </div> </div>	2	
13(c)	$P_{2022} = \frac{113.75 \times 58000}{100}$ $100 - m = \frac{49300}{65975^*} \times 100$ <div style="display: flex; align-items: center; justify-content: center;"> <div style="text-align: center;"> <p>(K1)</p> <p> </p> <p>(K1)</p> <p> </p> <p>[N1] (m =) 25.27</p> </div> </div>	3	
			10

(K1) menggunakan rumus

$$\frac{P_1}{P_0} \times 100$$

[N1], [N1] 3 jawapan betul

[N1] 2 jawapan betul

- 14 Azri mempunyai x buah bengkel kereta yang terletak di Sungai Petani dan y buah bengkel kereta yang terletak di Gurun. Pekerja-pekerja di bengkel tersebut dibahagikan kepada dua jenis tugas yang berbeza iaitu sebagai mekanik dan staf. Jadual 14 menunjukkan bilangan pekerja bagi setiap bengkel mengikut skop pekerjaan.
- Azri has x car workshops located in Sungai Petani and y car workshops located in Gurun. The workers in the workshop are divided into two different types of tasks, which are mechanics and staff. Table 14 shows the number of employees for each workshops according to the job scope.*

Bengkel kereta <i>Car workshop</i>	Bilangan pekerja bagi setiap bengkel <i>Number of workers in each workshop</i>	
	Mekanik <i>Mechanics</i>	Staf <i>staff</i>
Sungai Petani	9	3
Gurun	5	3

Jadual 14 / *Table 14*

Pengurusan bengkel-bengkel kereta itu berdasarkan kepada kekangan berikut :
The management of the car workshops are based on the following constraints:

- I Jumlah mekanik bagi Sungai Petani dan Gurun sekurang-kurangnya 90 orang.
The total number of mechanics for Sungai Petani and Gurun is at least 90 people.
 - II Bilangan maksimum staf bagi Sungai Petani dan Gurun ialah 51 orang.
The maximum number of staff for Sungai Petani and Gurun is 51 people.
 - III Nisbah bilangan bengkel kereta di Gurun kepada bilangan bengkel kereta di Sungai Petani tidak kurang daripada 1 : 2.
The ratio of the number of workers in Gurun to the number of workers in the Sungai Petani is not less than 1 : 2.
- (a) Tulis tiga ketaksamaan, selain daripada $x \geq 0$ dan $y \geq 0$, yang memenuhi semua kekangan di atas.
Write three inequalities, other than $x \geq 0$ and $y \geq 0$, which satisfy all of the above constraints.
- [3 markah / marks]
- (b) Menggunakan skala 2 cm kepada 2 buah bengkel pada kedua-dua paksi, bina dan lorek rantau R yang memenuhi semua kekangan di atas
Using a scale of 2 cm to 2 workshops on both axes, construct and shade the region R which satisfies all of the above constraints.
- [3 markah / marks]

Gunakan graf yang dibina di (b) untuk menjawab soalan-soalan berikut:
Use the graph constructed in (b) to answer the following questions:

- (c) (i) Nyatakan julat bilangan bengkel di Sungai Petani jika bilangan bengkel di Gurun ialah 7 buah.
State the range of the number of workshops in Sungai Petani if the number of workshops in Gurun is 7.
- (ii) Dengan melukis fungsi objektif, cari jumlah keuntungan minimum jika keuntungan setiap bengkel di Sungai Petani dan Gurun masing-masing ialah RM 50 000 dan RM 10 000.
By drawing the objective function, find the minimum amount of profit if the profit of each workshop in Sungai Petani and Gurun is RM 50 000 and RM 10 000 respectively.
- [4 markah / marks]

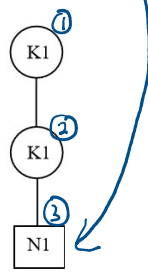
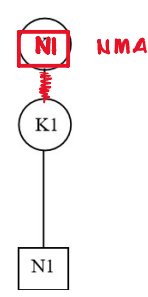
No.	SKEMA PEMARKAHAN	Sub Markah	Jumlah Markah	
14(a)	$9x + 5y \geq 90$ N1 $x + y \leq 17$ N1 $2y \geq x$ N1	3		
14(b)	<p>Lukis dengan betul sekurang-kurangnya Satu garis lurus dari* ketaksamaan yang Melibatkan x dan y yang bermula dari asalan.</p> <p>Lukis dengan betul semua *garis lurus dari * ketaksamaan yang melibatkan x dan y</p> <p>Rantau dilorek dengan betul</p> 	3		
14(c)(i)	$7 \leq x \leq 10$ N1	1		
14(c)(ii)	$50000x + 10000y = k$ Graf fungsi objektif dilukis $50000(2) + 10000(15)$ (RM)250 000		3	
			10	

Graf untuk soalan 14

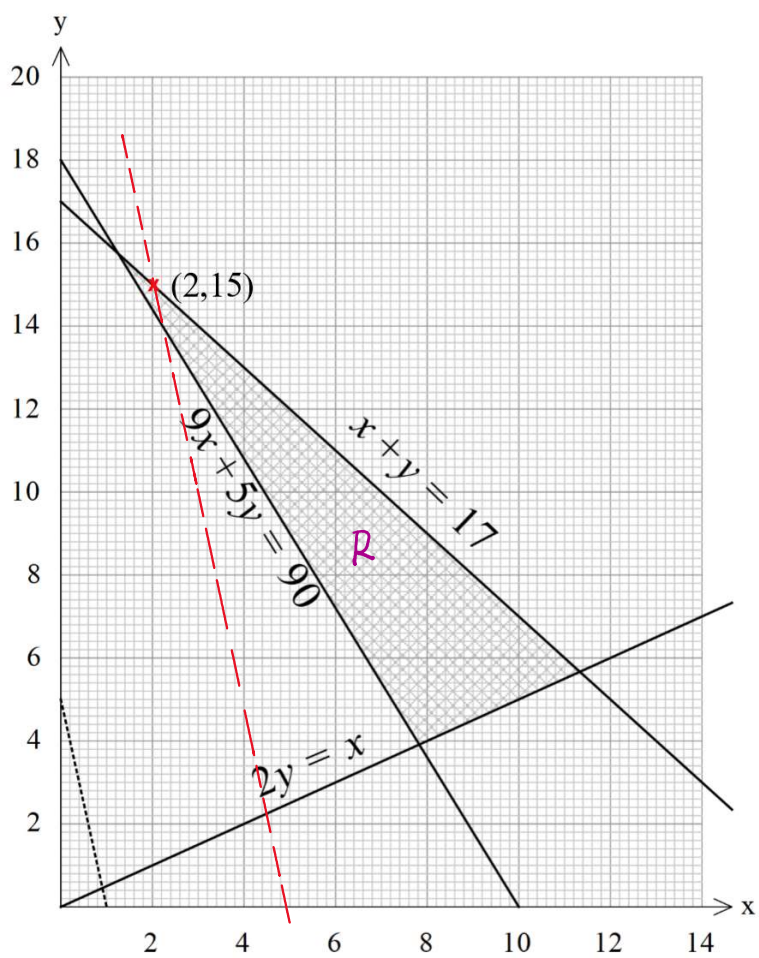

No.	SKEMA PEMARKAHAN	Sub Markah	Jumlah Markah
15(a)	6 ms^{-1} N1	1	
15(b)	<p>Bezakan V terhadap t</p> $\frac{dV}{dt} = 5$ <p>DAN</p> <p>Gantikan $t = \frac{1}{2}$</p> $2\left(\frac{1}{2}\right)t + 2$ <p>N1 $t = 3 \text{ s}$</p> <p>K1</p>	2	
15(c)	<p>Kamirkan $V_Q = \int a \, dt$</p> $V_Q = \frac{t^2}{2} + c$ <p>K1</p> <p>Gantikan $t = 0, V_Q = 14$ untuk dapatkan nilai c</p> <p>K1</p> <p>N1 $V_Q = \frac{t^2}{2} + 14$</p> <p>Samakan $V_p = V_Q$</p> $\frac{1}{2}t^2 + 2t + 6 = \frac{1}{2}t^2 + 14$ <p>K1</p> <p>N1 $t = 4 \text{ s}$</p> <p>Kamirkan $\int_0^8 V_Q \, dt$ dan gantikan nilai had \int_0^8</p> <p>K1</p> <p>N1 $197\frac{1}{3} \text{ m} @ \frac{592}{3} \text{ m} @ 197.33 \text{ m}$</p>	5	
15(d)	<p>K1</p> <p>N1</p>	2	
			10

PERATURAN PEMARKAHAN TAMAT