

KOLEJ YAYASAN SAAD
MELAKA
29 DIS 2022

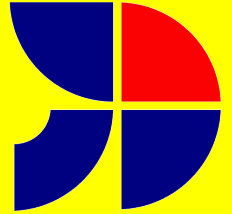

SPM PHYSICS 2022

'It's not about being the BEST.
'It's about being BETTER than
you were yesterday.'



#amazing Physics
amazing Physics with Tcer Alina

Maklumat berikut mungkin berfaedah. Simbol-simbol mempunyai makna yang biasa.
The following information may be useful. The symbols have their usual meaning.

1. FORCE AND MOTION I

$$a = \frac{v - u}{t}$$

$$s = \frac{1}{2}(u + v)t$$

$$s = ut + \frac{1}{2}at^2$$

$$v^2 = u^2 + 2as$$

$$\text{Momentum} = mv$$

$$F = ma$$

$$F = \frac{mv - mu}{t}$$

$$Ek = \frac{1}{2}mv^2$$

$$Ep = mgh$$

2. GRAVITATION

$$F = \frac{Gm_1m_2}{r^2}$$

$$g = \frac{GM}{r^2}$$

$$F = \frac{mv^2}{r}$$

$$a = \frac{v^2}{r}$$

$$v = \sqrt{\frac{GM}{r}}$$

$$v = \frac{2\pi r}{T}$$

$$U = -\frac{Gm_1m_2}{r}$$

$$v = \sqrt{\frac{2GM}{r}}$$

$$T^2 = \frac{4\pi^2 r^3}{GM}$$

$$\frac{T_1^2}{T_2^2} = \frac{r_1^3}{r_2^3}$$

$$g = 9.81 \text{ ms}^{-2} @ \text{N kg}^{-1}$$

$$G = 6.67 \times 10^{-11} \text{ N m}^2 \text{ kg}^{-2}$$

3. HEAT

$$Q = mc\theta$$

$$Q = ml$$

$$Q = Pt$$

$$P_1V_1 = P_2V_2$$

$$\frac{V_1}{T_1} = \frac{V_2}{T_2}$$

$$\frac{P_1}{T_1} = \frac{P_2}{T_2}$$

4. WAVES

$$f = \frac{1}{T}$$

$$v = f\lambda$$

$$\lambda = \frac{ax}{D}$$

5. LIGHT & OPTICS

$$n = \frac{c}{v}$$

$$n = \frac{\sin i}{\sin r}$$

$$n = \frac{1}{\sin C}$$

$$n = \frac{H}{h}$$

$$n_1 \sin \theta_1 = n_2 \sin \theta_2$$

$$\frac{1}{f} = \frac{1}{u} + \frac{1}{v}$$

$$\text{Linear magnification, } m = \frac{v}{u}$$

The **KEY** to **SUCCESS** is to start **BEFORE** you are **READY**

6. FORCE AND MOTION II

$$F = kx$$

$$E = \frac{1}{2} Fx$$

$$E = \frac{1}{2} kx^2$$

7. PRESSURE

$$P = \frac{F}{A}$$

$$P = h\rho g$$

$$\rho = \frac{m}{V}$$

$$\frac{F_1}{A_1} = \frac{F_2}{A_2}$$

$$A_1 h_1 = A_2 h_2$$

$$F_b = \rho V g$$

8. ELECTRICITY

$$E = \frac{F}{Q}$$

$$I = \frac{Q}{t}$$

$$V = \frac{E}{Q}$$

$$V = IR$$

$$R = \frac{\rho l}{A}$$

$$E = V + Ir$$

$$P = IV$$

$$P = \frac{V^2}{R}$$

$$P = I^2 R$$

$$P = \frac{E}{t}$$

$$E = \frac{F}{d}$$

9. ELECTROMAGNETISME

$$\frac{V_S}{V_P} = \frac{N_S}{N_P}$$

$$n = \frac{\text{Output power}}{\text{Input power}} \times 100\%$$

10. ELECTRONIC

$$E = eV$$

$$E = \frac{1}{2} mv^2$$

$$\beta = \frac{I_C}{I_B}$$

$$e = 1.66 \times 10^{-19} \text{ C}$$

11. PHYSICS NUCLEAR

$$N = \left(\frac{1}{2}\right)^n N_0$$

$$E = mc^2$$

$$c = 3.00 \times 10^8 \text{ m s}^{-1}$$

$$1 \text{ a.m.u.} = 1.66 \times 10^{-27} \text{ kg}$$

12. QUANTUM PHYSICS

$$E = hf$$

$$f = \frac{c}{\lambda}$$

$$\lambda = \frac{h}{p}$$

$$\lambda = \frac{h}{mv}$$

$$E = \frac{hc}{\lambda}$$

$$P = nhf$$

$$hf = W + \frac{1}{2} mv^2_{\text{maks}}$$

$$W = hf_0$$

$$h = 6.63 \times 10^{-34} \text{ J s}$$

$$e = 1.66 \times 10^{-19} \text{ C}$$

Stay
FOCUSED
 and
NEVER
 GIVE UP

Section A

[60 marks]

Answer **all** questions in this section.

- 1 Diagram 1 shows a circuit which is used to determine the internal resistance, r of a dry cell.

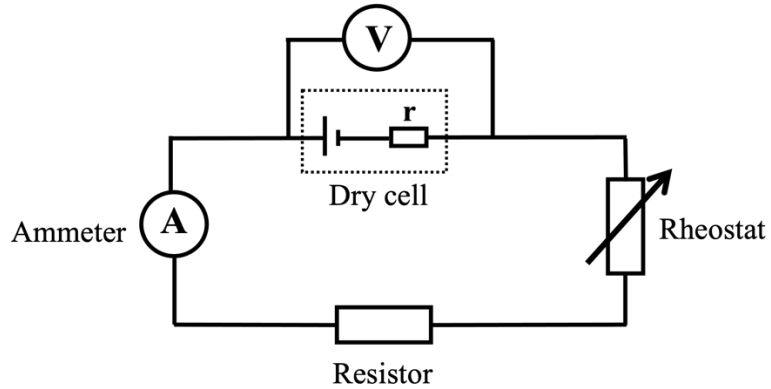

Diagram 1

- (a) Name the physical quantity that measured by the voltmeter.

.....
[1 mark]

- (b) Based on the Diagram 1, sketch the expected voltage against current graph.

[2 marks]

- (c) What happened to the internal resistance, r if the dry cell is used for a long time?

.....
[1 mark]

TOTAL 4 marks

- 2 Diagram 2.1 and Diagram 2.2 show two rectangular glass blocks with different optical density and refractive index. Ray of light is directed toward the glass blocks with the same angle of incidence 30° .

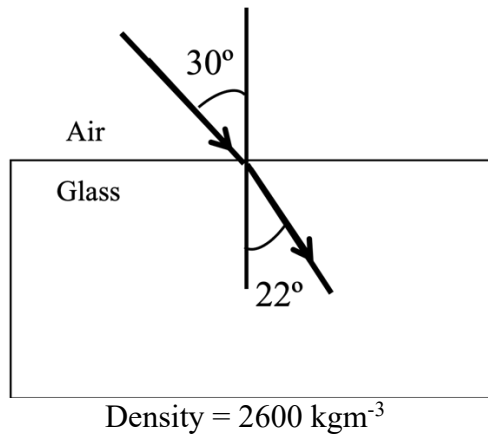

Diagram 2.1

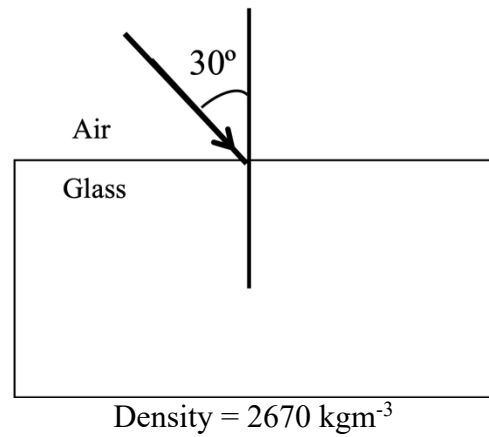

Diagram 2.2

- (a) What is meant by refraction?

.....
[1 mark]

- (b) Calculate the refractive index of the glass block in Diagram 2.1.

[2 marks]

- (c) (i) On Diagram 2.2, draw the light path when the light passes through a glass block.

[1 mark]

- (ii) Give a reason.

.....
[1 mark]

TOTAL 5 marks

- 3 Diagram 3.1 shows two n-type semiconductor materials and n-type semiconductors are combined and then connected to a cell and a bulb. When the current is turned on, the bulb light up.

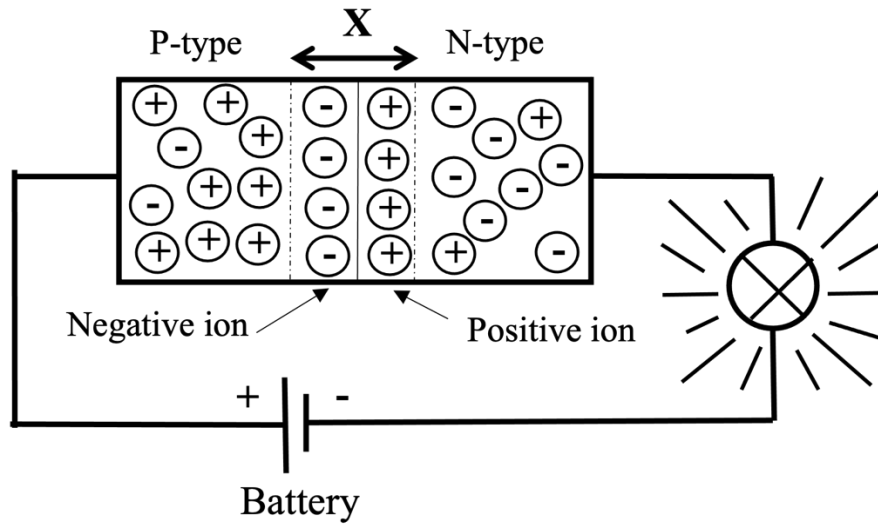

Diagram 3.1

- (a) Name the part label X?

..... [1 mark]

- (b) The cell terminal in Diagram 3.1 is then reversed.

- (i) What happens to the distance of X.

..... [1 mark]

- (ii) State the condition of the bulb.
Explain.

.....
.....

[2 marks]

- (c) Diagram 3.2 shows a boron (B) atom embedded among silicon (Si) atoms in a semiconductor.
 In Diagram 3.3 the embedded atom is phosphorus (P).

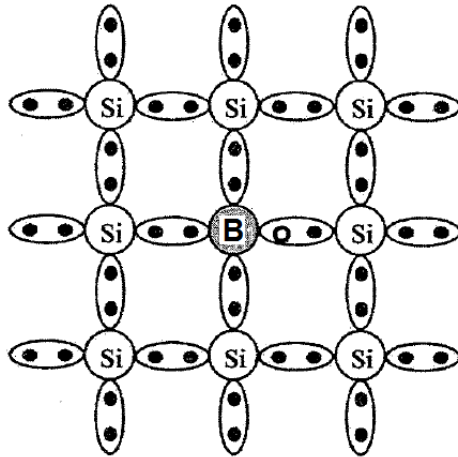

Diagram 3.2

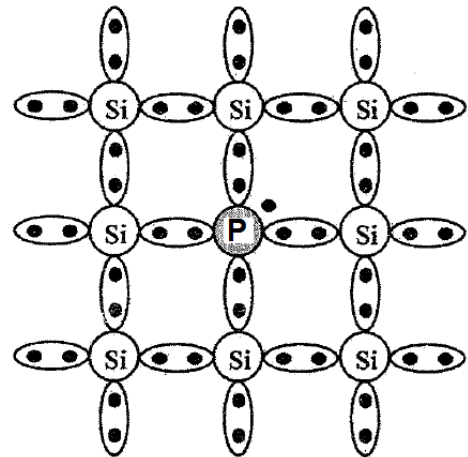

Diagram 3.3

- (i) What is the purpose of doping a semiconductor?

.....
 [1 mark]

- (ii) Name the type of semiconductor as shown on Diagram 3.2.

.....
 [1 mark]

TOTAL 6 marks

- 4 Diagram 4.1 show the image form of convex lenses, from a ray box with triangle hole as an object.

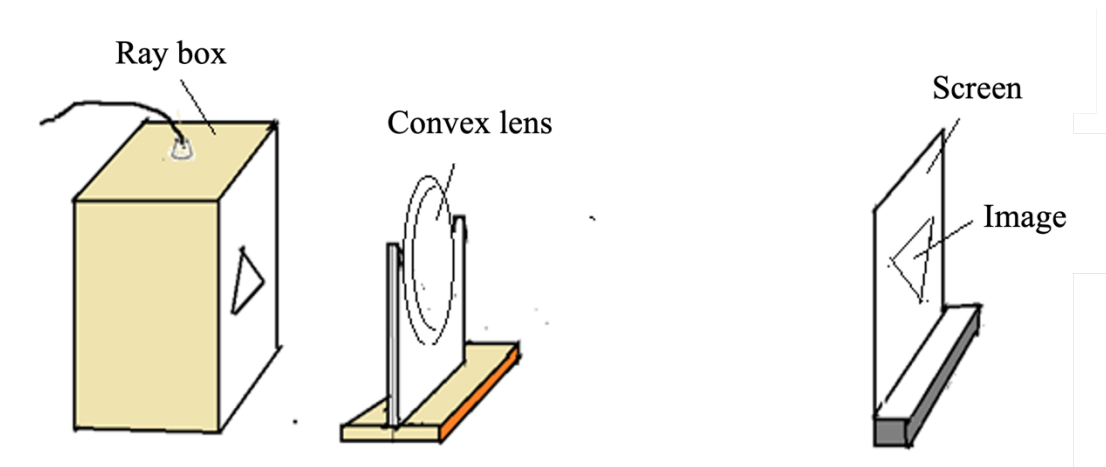

Diagram 4.1

- (a) **Underline** the **correct** answer.

Image form of the convex lens is (real, virtual)

[1 mark]

- (b) On Diagram 4.1, label the image distance.

[1 mark]

- (c) Based on Diagram 4.1, draw a ray diagram to show the image form on the screen in the space below.

[3 marks]

- (d) Diagram 4.2 shows the student used a slide projector to display a large sharp image on the screen.

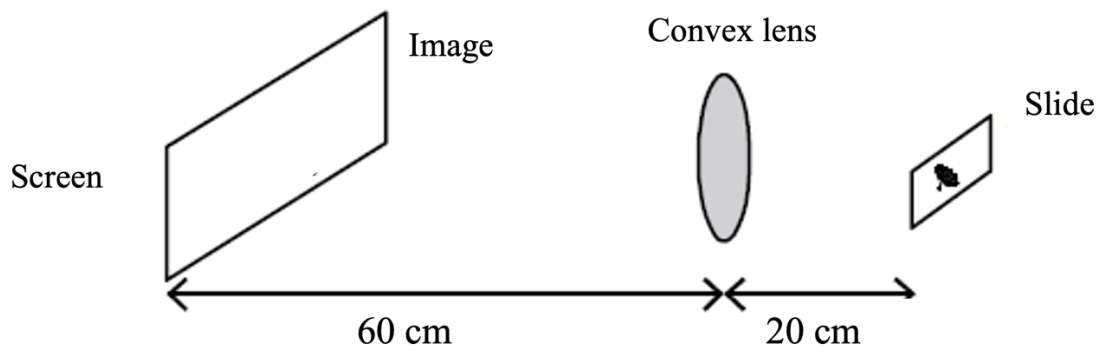

Diagram 4.2

- (i) Based on Diagram 4.2, calculate the focal length of lens, f .

[2 marks]

- (ii) Draw the image formed on the screen in Diagram 4.2.

[1 mark]

- (iii) State **one** characteristics of the image formed.

.....
[1 mark]

TOTAL 9 marks

5 Diagram 5.1 and Diagram 5.2 show trapped gas being heated in an enclosed space.

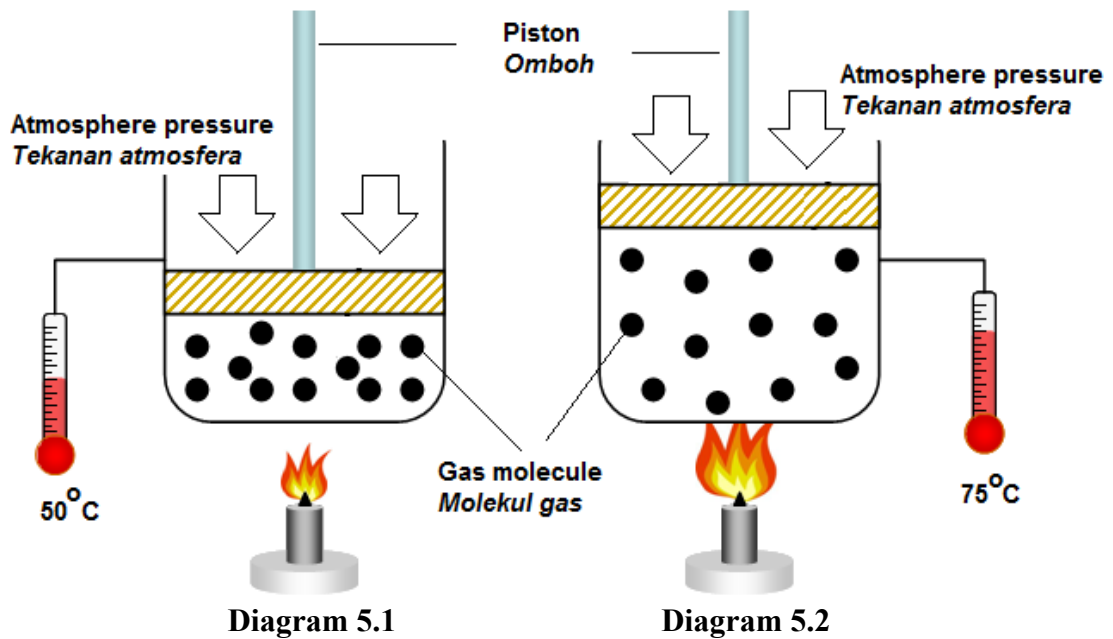

(a) What is the meaning of absolute temperature?

.....
[1 mark]

(b) Observe Diagram 5.1 and Diagram 5.2. Compare

(i) heat given.

.....
[1 mark]

(ii) temperature of gas.

.....
[1 mark]

(iii) volume of gas.

.....
[1 mark]

(c) Based on answer in 5(b), state the relationship between the temperature and

(i) heat

.....
[1 mark]

(ii) volume of gas.

.....
[1 mark]

(d) Name the law involved when the pressure is kept constant.

.....
[1 mark]

(e) Air with temperature of $27\text{ }^{\circ}\text{C}$ and volume of 0.24 m^3 is in a cylinder with constant pressure. What is the volume of the air at temperature of $80\text{ }^{\circ}\text{C}$?

[2 marks]

TOTAL 9 marks

- 6 Diagram 6.1(a), Diagram 6.1(b) and Diagram 6.1(c) show a beaker filled with water. The level of water in the beaker changes when the number of fingers immersed into water increases.

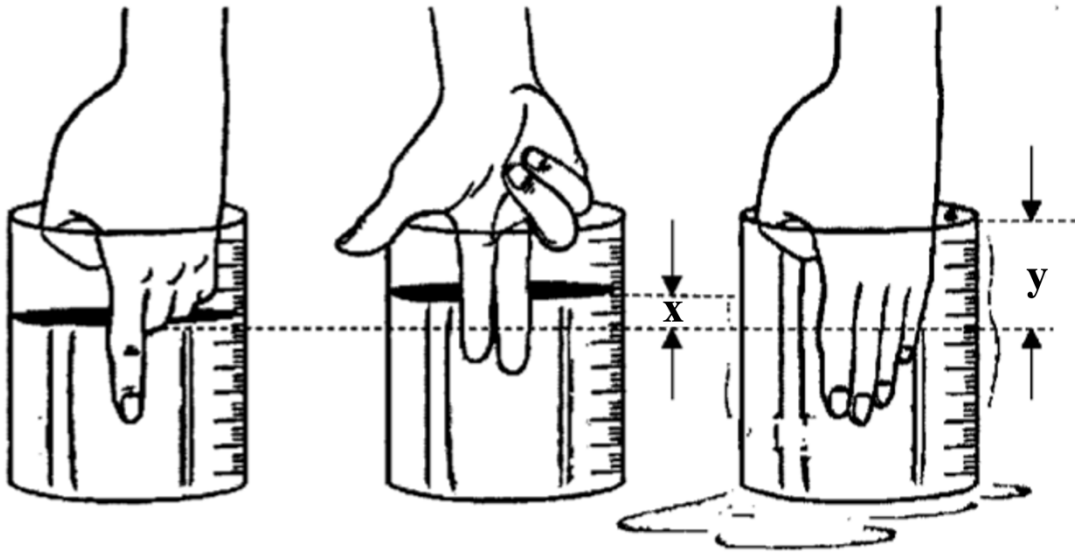

Diagram 6.1(a)

Diagram 6.1(b)

Diagram 6.1(c)

- (a) Name one force acted on the fingers.

 [1 mark]
- (b) Observe Diagram 6.1(b) and Diagram 6.1(c).
 (i) Compare the number of fingers immersed into the water.

 [1 mark]
- (ii) Compare the water level difference x and y .

 [1 mark]
- (iii) Compare the volume of water displaced.

 [1 mark]
- (c) Based on answer in 6(b), state the relationship between the force acted on the fingers and
 (i) the number of fingers immersed into the water

 [1 mark]

- (ii) the volume of water displaced.

.....
[1 mark]

- (d) The water in the beaker is replaced with liquid P of a higher density.

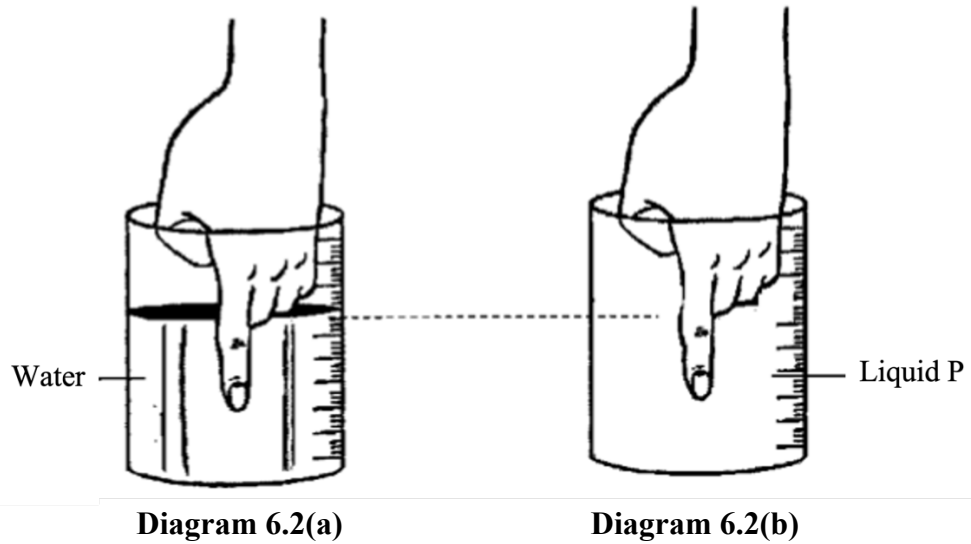

- (i) On Diagram 6.2(b), mark the level of liquid P in the beaker compared to the water level in Diagram 6.2(a).
[1 mark]
- (ii) The density of liquid P is $1\,300\text{ kgm}^{-3}$ and the volume of liquid P displaced is 0.15 m^3 .
Calculate force acted on the fingers.

[2 marks]

TOTAL 9 marks

7 Diagram 7 shows an athlete spinning a hammer in an hammer throw sport event.

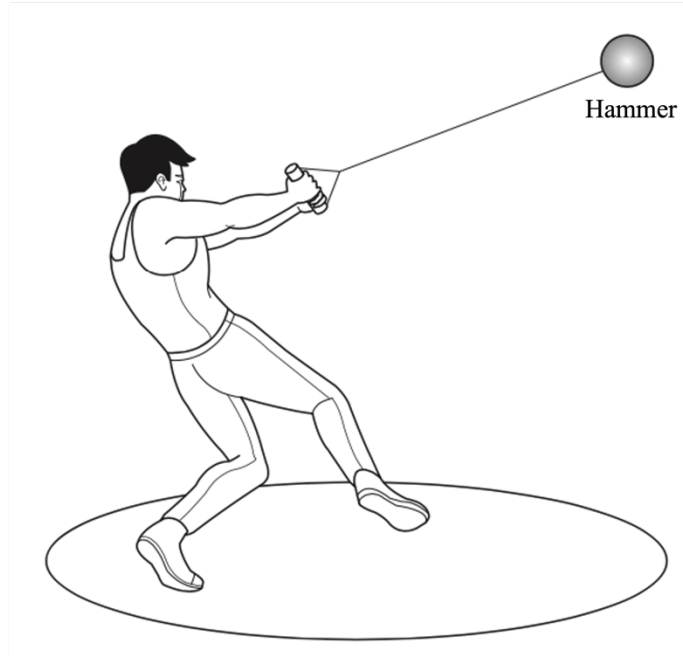

Diagram 7

The centripetal force acting on the hammer when rotated is the tension of string.

(a) What is centripetal force?

.....
[1 mark]

(b) On Diagram 7, mark the direction of the centripetal force, F , acting on the hammer.

[1 mark]

(c) The hammer of mass 5 kg is rotated in a horizontal circle of radius 1.6 m with a linear speed of 25 m s^{-1} .
Calculate the centripetal force acted on the hammer.

[2 marks]

- (d) Table 7 shows the characteristics of the hammer A, B and C throws involved in a hammer throw sport event.

Hammer throw	Length of steel string (m)	Linear speed of the hammer, when it is rotated (m s^{-1})
A	1.85	24
B	1.55	20
C	1.15	29

Table 7

Based on the specifications in Table 7, state the suitable characteristics of the hammer throw that has the highest rope tension when it is rotated.

Give reason for the suitability for each of the characteristic.

- (i) Length of steel string

.....
[1 mark]

Reason

.....
[1 mark]

- (ii) Linear speed of the hammer, when it is rotated

.....
[1 mark]

Reason

.....
[1 mark]

- (e) Based on the answer in 7 (d), which hammer throw has the highest rope tension when it is rotated?

.....
[1 mark]

TOTAL 9 marks

8 Diagram 8.1 shows a hydrogen line spectrum.



Diagram 8.1

Coloured lines formed have specific wavelength, frequency and quantum energy.

(a) What is meant by quantum energy?

.....
[1 mark]

(b) (i) A coloured line from line spectrum of hydrogen atom has a wavelength of 486 nm. Determine the photon's energy of the coloured line.

[Planck's constant, $h = 6.63 \times 10^{-34} \text{ J s}$]

[Speed of light in vacuum, $c = 3.00 \times 10^8 \text{ m s}^{-1}$]

[2 marks]

(ii) Based on your answer in 8(b)(i), if the number of photons emitted is $3.37 \times 10^{18} \text{ s}^{-1}$, calculate the output power of the coloured line.

[2 marks]

(c) Diagram 8.2 shows a simple solar panel.

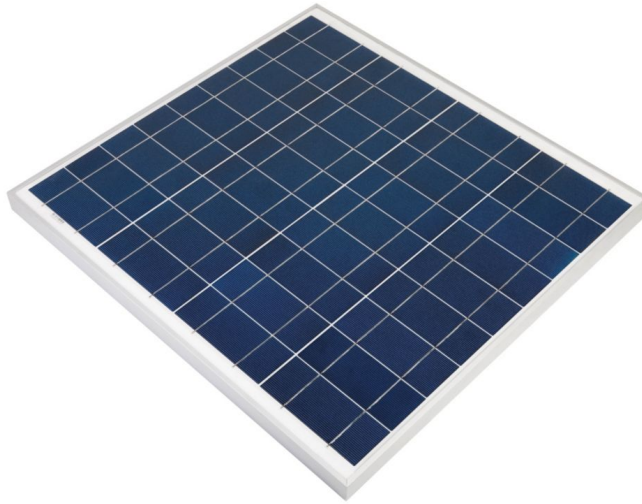

Diagram 8.2

Suggest modification that can be made so that the solar panel can be used to absorb more light and convert to larger electrical energy based on the following aspect:

(i) Work function of material used

.....
Reason [1 mark]

.....
[1 mark]

(ii) Surface area

.....
Reason [1 mark]

.....
[1 mark]

TOTAL 9 marks

Section B

[20 marks]

Answer any **one** question in this section.

- 9 Diagram 9.1 shows a bat using ultrasonic waves to detect obstacle in front of it.

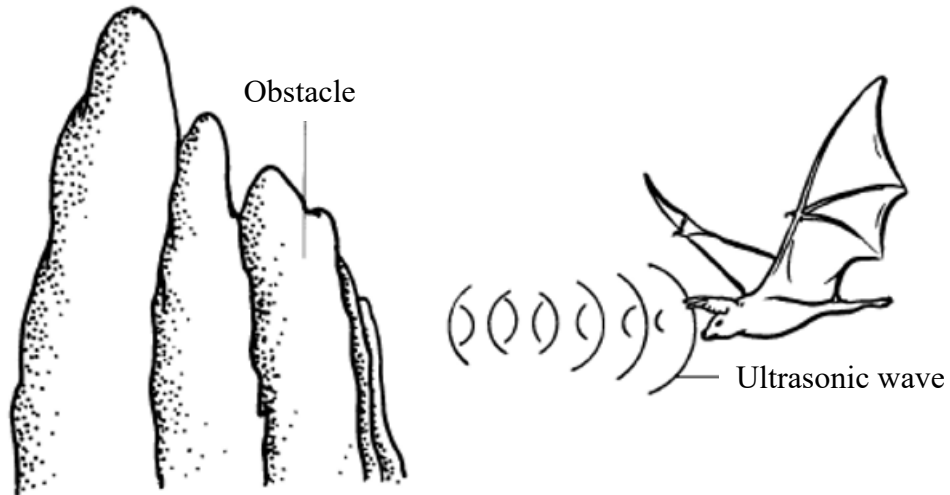

Diagram 9.1

- (a) (i) What is the meaning of ultrasonic wave? [1 mark]
- (ii) Explain how the ultrasonic waves are used by the bat to detect the distance of the obstacle. [4 marks]
- (b) A beam of sonar with speed 1450 m s^{-1} sent to a shoal of fish underneath a fishing boat.
- (i) The depth of the shoal of fish when the echo returns after 100 milliseconds. [3 marks]
- (ii) The wavelength of the sonar waves when its frequency is 40 kHz. [2 marks]

- (c) Three classrooms in your school are combined to become a lecture hall.
Table 1 shows four types of sound system to be used in the hall.

Sound system	Location of the loud speakers	Distance between two loud speakers	Material used to cover the wall	The position of the microphone
W	High	Small	Softboard	Behind the speaker
X	Low	Large	Hardwood	In front of the speaker
Y	High	Large	Softboard	Behind the speaker
Z	Low	Small	Hardwood	In front of the speaker

Table 1

You are asked to investigate the design of the sound system to produce better quality of sound.

Explain the suitability of each characteristic of the sound system.

Determine the most suitable sound system.

Give reasons for your choice.

[10 marks]

TOTAL 20 marks

- 10 Diagram 10.1 shows a hydraulic jack which used to lift the side of a car. The working principle of the hydraulic jack is based on the Pascal's principle.



Diagram 10.1

- (a) (i) State the Pascal's Principle. [1 mark]
(ii) Explain how the hydraulic jack can be used to lift the side of the car. [4 marks]
- (b) Diagram 10.2 shows a hydraulic brake system in a car.

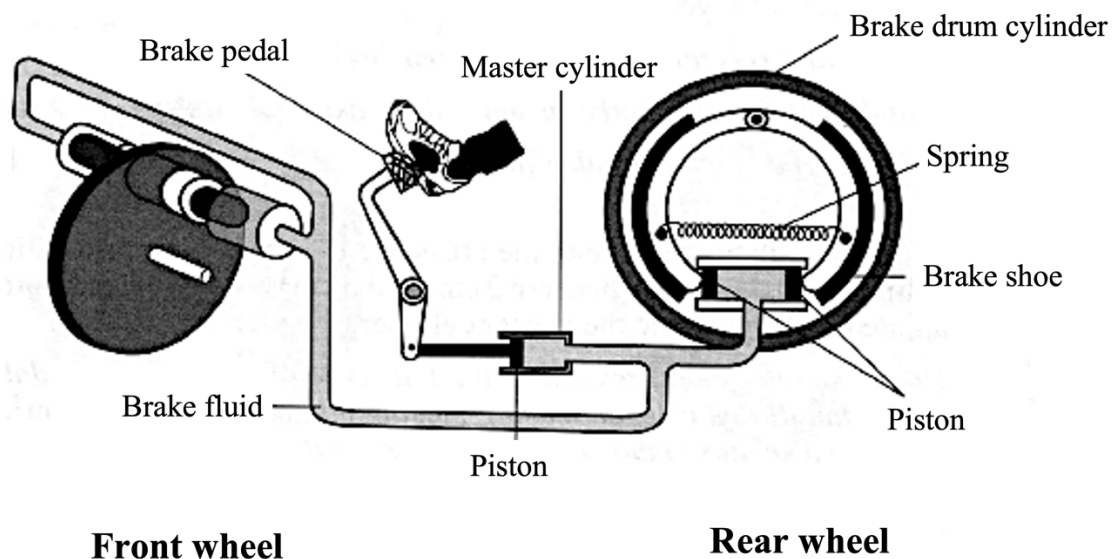

Diagram 10.2

You are required to investigate the characteristics of a hydraulic brake system as shown in Table 2.

Hydraulic brake	Type of fluid	Boiling point of brake fluid	Spring constant	Ratio of cross-section area of pistons in the master cylinder to the brake drum cylinder
P	Water	Low	Low	1:1
Q	Oil	High	High	1:5
R	Water	High	High	1:1
S	Oil	Low	Low	3:2

Table 2

Determine the most effective hydraulic brake to be used in a car brake system. Give reasons for your choice.

[10 marks]

- (c) In a hydraulic brake system, the cross-section area of the pistons in the master cylinder and the front wheel are 2 cm^2 and 6 cm^2 respectively. A force of 50 N is applied to the piston in the master cylinder.

Calculate;

- (i) the pressure transmitted throughout the brake fluid.

[2 marks]

- (ii) the force exerted on the piston of the front wheel in S.I. base unit.

[3 marks]

TOTAL 20 marks

Section C

[20 marks]

Answer **all** questions in this section.

11. Diagram 11.1 and Diagram 11.2 show an experiment to study a current-carrying conductor in a magnetic field.

When the switch is closed, the combination of the magnetic field and the current produced a resultant force. The copper rod pushed out at distance, d_1 . When the current is changed, the distance of copper rod change to d_2 .

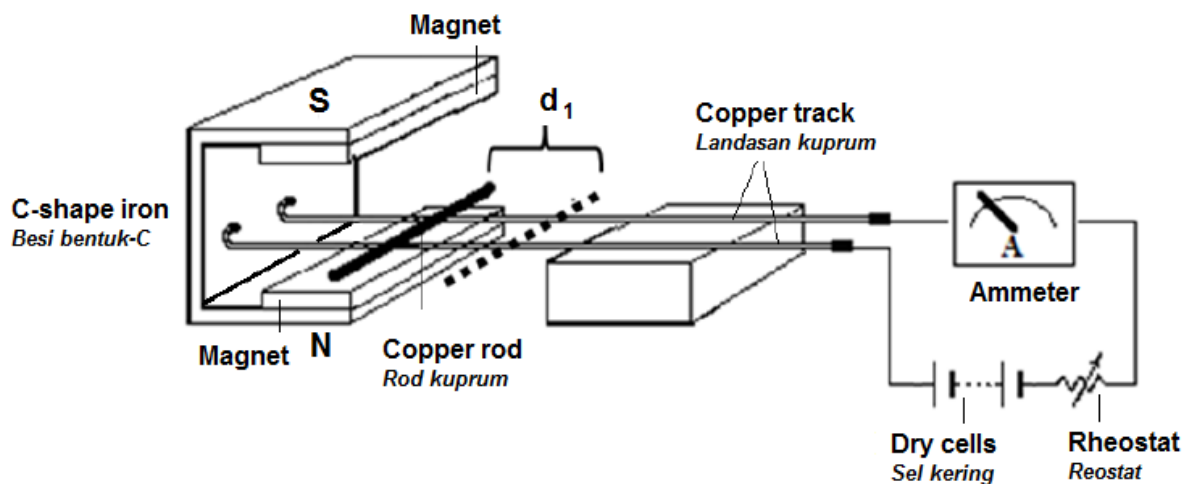

Diagram 11.1

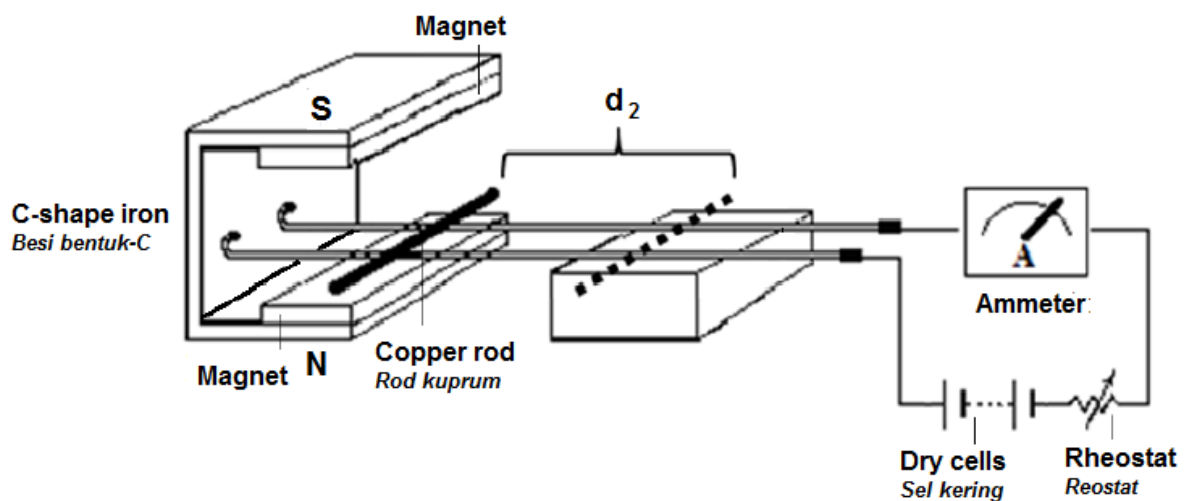

Diagram 11.2

- (a) Name the rule used to determine the direction of the force.

[1 mark]

- (b) Based on Diagram 11.1 and Diagram 11.2, compare ammeter reading, distance of copper rod and the magnitude of force produced.

State the relationship between electric current with distance of copper rod and the magnitude of force produced.

[5 marks]

- (c) Diagram 11.3 shows a wire is connected to a galvanometer which placed between two magnets of opposite poles.

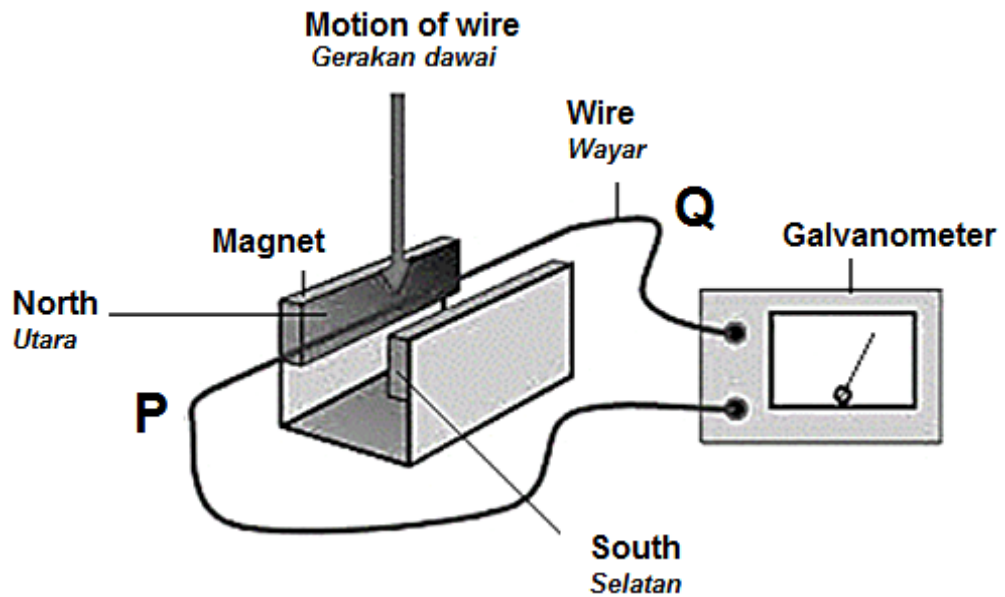

Diagram 11.3

Explain:

- (i) why the galvanometer shows a reading when the wire is moved downwards.

[2 marks]

- (ii) how to determine the direction of the current produced in the wire.

[2 marks]

(d) Diagram 11.4 shows an ac generator.

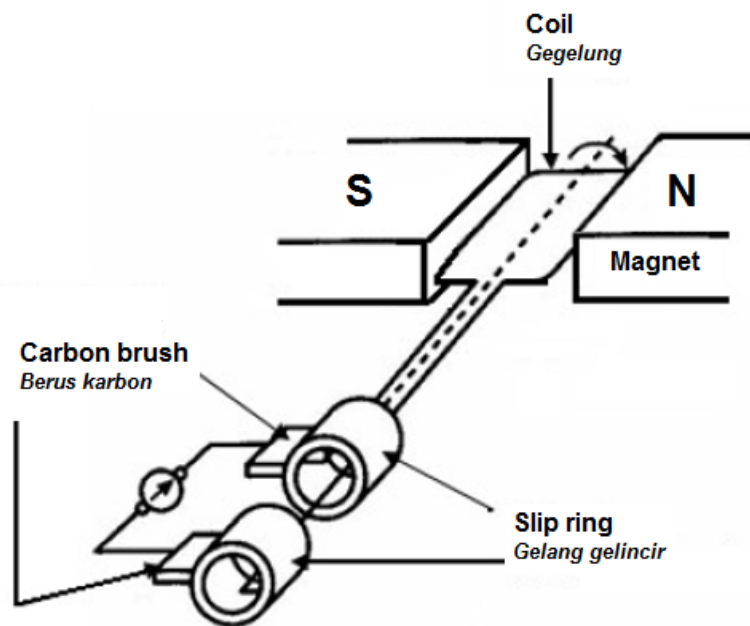

Diagram 11.4

Suggest modifications that can be made to increase the output current to the generator in Diagram 10.4.

State and explain the modifications based on the following aspects:

- (i) Strength of the magnet
- (ii) Shape of the magnet
- (iii) Number of turns of the coil
- (iv) Diameter of the wire of the coil
- (v) The speed of rotation.

[10 marks]

TOTAL

20 marks

EXTRA!

- 11 Diagram 11.1 a test tube filled with lead shots floating upright in water of density 1 g cm^{-3} . Diagram 11.2 the same test tube filled with lead shots floating upright in oil of density 0.9 g cm^{-3} .

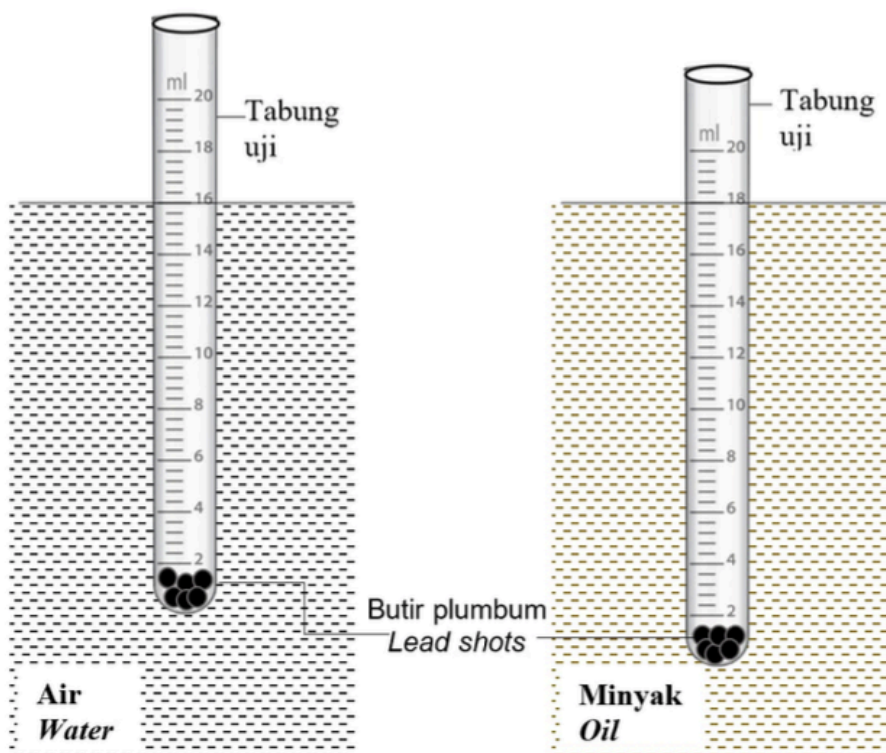

Diagram 11.1

Diagram 11.2

- (a) Name the physics principle involved in Diagram 11.1? [1 mark]
- (b) Observe Diagram 11.1 and Diagram 11.2,
- compare the density of liquid, depth of test tube immersed in liquid and volume of liquid displaced. [3 marks]
 - state the relationship between the density of liquid and depth of test tube immersed in liquid. Make a deduction regarding the relationship between the density of liquid and volume of liquid displaced to study the physics principle in 11(a). [2 marks]

- (c) Diagram 11.3 shows a dropper made into a Cartesian diver and is floating in a plastic bottle filled with water.

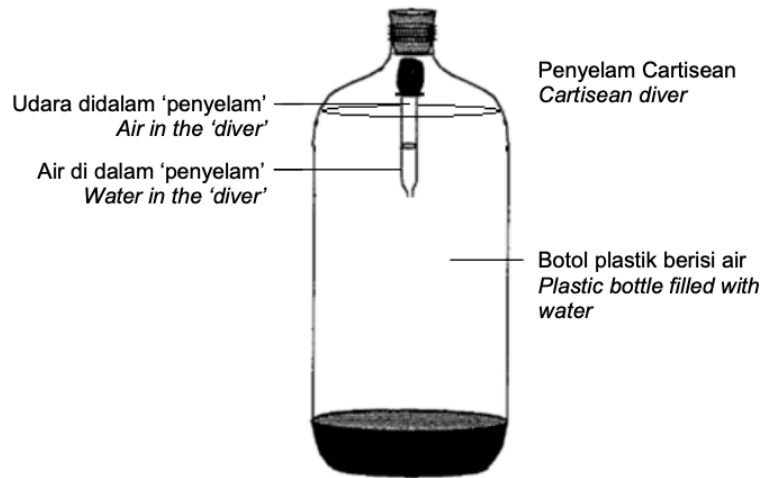

Diagram 11.3

Describe what happens to the Cartesian diver when the plastic bottle is squeezed.

[4 marks]

- (d) Cartesian diver in Diagram 11.3 can be used to understand the working principle of an old submarine as shown in Diagram 11.4.

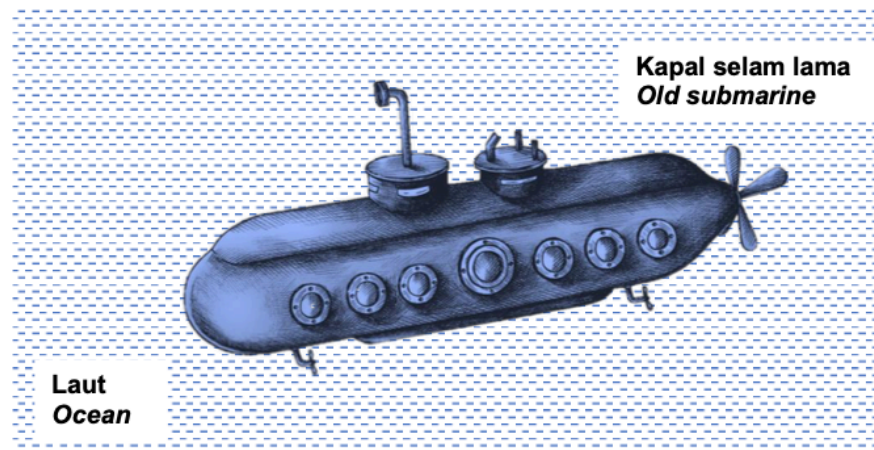

Diagram 11.4

Using appropriate physics concept, suggest modifications that need to be done to the old submarine in Diagram 11.4 so that it can dive to thousands of metres below the surface of the ocean, able to rise and sink easily, can navigate under the water safely and remain underwater for several months.

[10 marks]

TOTAL 20 marks

The best and most beautiful things in the world cannot be seen or even touched: they must be felt with the heart.

-Helen Keller-